

16-BIT, 1.25 MSPS, PSEUDO-BIPOLAR, FULLY DIFFERENTIAL INPUT, MICRO POWER SAMPLING ANALOG-TO-DIGITAL CONVERTER WITH PARALLEL INTERFACE

FEATURES

- Pseudo-Bipolar, Fully Differential Input, $-V_{REF}$ to V_{REF}
- 16-Bit NMC at 1.25 MSPS
- ± 2 LSB INL Max, $-1/+1.25$ LSB DNL
- 90 dB SNR, -95 dB THD at 100 kHz Input
- Zero Latency
- Internal 4.096 V Reference
- High-Speed Parallel Interface
- Single 5 V Analog Supply
- Wide I/O Supply: 2.7 V to 5.25 V
- Low Power: 155 mW at 1.25 MHz Typ
- Pin Compatible With ADS8412/8402
- 48-Pin TQFP Package

APPLICATIONS

- DWDM
- Instrumentation
- High-Speed, High-Resolution, Zero Latency Data Acquisition Systems
- Transducer Interface
- Medical Instruments
- Communications

DESCRIPTION

The ADS8406 is a 16-bit, 1.25 MHz A/D converter with an internal 4.096-V reference. The device includes a 16-bit capacitor-based SAR A/D converter with inherent sample and hold. The ADS8406 offers a full 16-bit interface and an 8-bit option where data is read using two 8-bit read cycles.

The ADS8406 has a pseudo-bipolar, fully differential input. It is available in a 48-lead TQFP package and is characterized over the industrial -40°C to 85°C temperature range.

High Speed SAR Converter Family

Type/Speed	500 kHz	580 kHz	750 MHz	1.25 MHz	2 MHz	3 MHz	4 MHz
18 Bit Pseudo-Diff	ADS8383	ADS8381					
16 Bit Pseudo-Diff			ADS8371	ADS8401	ADS8411		
				ADS8405			
16 Bit Pseudo Bipolar, Fully Differential				ADS8402	ADS8412		
				ADS8406			
14 Bit Pseudo-Diff				ADS7890 (S)		ADS7891	
12 Bit Pseudo-Diff							ADS7881

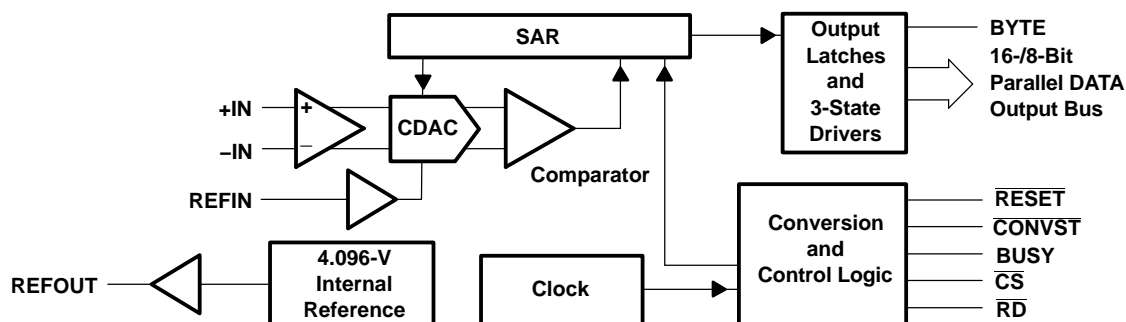

Please be aware that an important notice concerning availability, standard warranty, and use in critical applications of Texas Instruments semiconductor products and disclaimers thereto appears at the end of this data sheet.

ORDERING INFORMATION⁽¹⁾

MODEL	MAXIMUM INTEGRAL LINEARITY (LSB)	MAXIMUM DIFFERENTIAL LINEARITY (LSB)	NO MISSING CODES RESOLUTION (BIT)	PACKAGE TYPE	PACKAGE DESIGNATOR	TEMPERATURE RANGE	ORDERING INFORMATION	TRANSPORT MEDIA QUANTITY
ADS8406I	-4 to +4	-2 to +2	15	48 Pin TQFP	PFB	-40°C to 85°C	ADS8406IPFBT	Tape and reel 250
							ADS8406IPFBR	Tape and reel 1000
ADS8406IB	-2 to +2	-1 to +1.25	16	48 Pin TQFP	PFB	-40°C to 85°C	ADS8406IBPFBT	Tape and reel 250
							ADS8406IBPFBR	Tape and reel 1000

(1) For the most current specifications and package information, refer to our website at www.ti.com.

ABSOLUTE MAXIMUM RATINGS

over operating free-air temperature range unless otherwise noted⁽¹⁾

		UNIT
Voltage	+IN to AGND	-0.4 V to +VA + 0.1 V
	-IN to AGND	-0.4 V to +VA + 0.1 V
Voltage range	+VA to AGND	-0.3 V to 7 V
	+VBD to BDGND	-0.3 V to 7 V
	+VA to +VBD	-0.3 V to 2.55 V
Digital input voltage to BDGND		-0.3 V to +VBD + 0.3 V
Digital output voltage to BDGND		-0.3 V to +VBD + 0.3 V
T _A	Operating free-air temperature range	-40°C to 85°C
T _{stg}	Storage temperature range	-65°C to 150°C
Junction temperature (T _J max)		150°C
TQFP package	Power dissipation	(T _J Max - T _A)/θ _{JA}
	θ _{JA} thermal impedance	86°C/W
Lead temperature, soldering	Vapor phase (60 sec)	215°C
	Infrared (15 sec)	220°C

(1) Stresses beyond those listed under *absolute maximum ratings* may cause permanent damage to the device. These are stress ratings only, and functional operation of the device at these or any other conditions beyond those indicated under *recommended operating conditions* is not implied. Exposure to absolute-maximum-rated conditions for extended periods may affect device reliability.

SPECIFICATIONS
 $T_A = -40^\circ\text{C}$ to 85°C , $+V_A = 5\text{ V}$, $+V_{BD} = 3\text{ V}$ or 5 V , $V_{ref} = 4.096\text{ V}$, $f_{SAMPLE} = 1.25\text{ MHz}$ (unless otherwise noted)

PARAMETER		TEST CONDITIONS	MIN	TYP	MAX	UNIT
ANALOG INPUT						
Full-scale input voltage ⁽¹⁾		+IN -- IN	$-V_{ref}$		V_{ref}	V
Absolute input voltage		+IN	-0.2		$V_{ref} + 0.2$	V
		-IN	-0.2		$V_{ref} + 0.2$	
Input capacitance				25		pF
Input leakage current				0.5		nA
SYSTEM PERFORMANCE						
Resolution				16		Bits
No missing codes		ADS8406I	15			Bits
		ADS8406IB	16			
Integral linearity ⁽²⁾⁽³⁾		ADS8406I	-4	± 2	4	LSB
		ADS8406IB	-2	± 1	2	
Differential linearity		ADS8406I	-2	± 1	2	LSB
		ADS8406IB	-1	± 0.5	1.25	
Offset error ⁽⁴⁾		ADS8406I	-2.5	± 1	2.5	mV
		ADS8406IB	-1.5	± 0.5	1.5	mV
Gain error ⁽⁴⁾⁽⁵⁾		ADS8406I	-0.12		0.12	%FS
		ADS8406IB	-0.098		0.098	
Common-Mode Rejection Ratio		At dc (0.2 V around $V_{ref}/2$)		80		dB
		+IN - -IN = 1 V_{pp} at 1 MHz		80		
DC Power supply rejection ratio		At 7FFFh output code, $+V_A = 4.75\text{ V}$ to 5.25 V , $V_{ref} = 4.096\text{ V}$, ⁽⁴⁾		2		LSB
SAMPLING DYNAMICS						
Conversion time					650	ns
Acquisition time			150			ns
Throughput rate					1.25	MHz
Aperture delay				2		ns
Aperture jitter				25		ps
Step response				100		ns
Overvoltage recovery				100		ns
DYNAMIC CHARACTERISTICS						
Total harmonic distortion (THD) ⁽⁶⁾		$V_{IN} = 8\text{ V}_{pp}$ at 100 kHz		-95		dB
		$V_{IN} = 8\text{ V}_{pp}$ at 500 kHz		-90		
Signal-to-noise ratio (SNR)		$V_{IN} = 8\text{ V}_{pp}$ at 100 kHz		90		dB
Signal-to-noise + distortion (SINAD)		$V_{IN} = 8\text{ V}_{pp}$ at 100 kHz		88		dB
Spurious free dynamic range (SFDR)		$V_{IN} = 8\text{ V}_{pp}$ at 100 kHz		95		dB
		$V_{IN} = 8\text{ V}_{pp}$ at 500 kHz		93		
-3dB Small signal bandwidth				5		MHz
EXTERNAL VOLTAGE REFERENCE INPUT						
Reference voltage at REFIN, V_{ref}			2.5	4.096	4.2	V
Reference resistance ⁽⁷⁾				500		k Ω

(1) Ideal input span, does not include gain or offset error.

(2) LSB means least significant bit

(3) This is endpoint INL, not best fit.

(4) Measured relative to an ideal full-scale input (+IN -- IN) of 8.192 V

(5) This specification does not include the internal reference voltage error and drift.

(6) Calculated on the first nine harmonics of the input frequency

(7) Can vary $\pm 20\%$

SPECIFICATIONS (continued)

$T_A = -40^{\circ}\text{C}$ to 85°C , $+VA = 5\text{ V}$, $+VBD = 3\text{ V}$ or 5 V , $V_{\text{ref}} = 4.096\text{ V}$, $f_{\text{SAMPLE}} = 1.25\text{ MHz}$ (unless otherwise noted)

PARAMETER		TEST CONDITIONS	MIN	TYP	MAX	UNIT
INTERNAL REFERENCE OUTPUT						
Internal reference start-up time		From 95% (+VA) with 1- μF storage capacitor			120	ms
V_{ref} range		$\text{IOUT} = 0$	4.065	4.096	4.13	V
Source current		Static load			10	μA
Line regulation		$+VA = 4.75$ to 5.25 V		0.6		mV
Drift		$\text{IOUT} = 0$		36		PPM/C
DIGITAL INPUT/OUTPUT						
Logic family - CMOS						
Logic level	V_{IH}	$\text{I}_{\text{IH}} = 5\ \mu\text{A}$	$+VBD-1$		$+VBD + 0.3$	V
	V_{IL}	$\text{I}_{\text{IL}} = 5\ \mu\text{A}$	-0.3		0.8	
	V_{OH}	$\text{I}_{\text{OH}} = 2\text{ TTL loads}$	$+VBD - 0.6$		$+VBD$	
	V_{OL}	$\text{I}_{\text{OL}} = 2\text{ TTL loads}$	0		0.4	
Data format			2's complement			
POWER SUPPLY REQUIREMENTS						
Power supply voltage	+VBD		2.7	3	5.25	V
	+VA		4.75	5	5.25	V
Supply current, $+VA^{(8)}$		$f_s = 1.25\text{ MHz}$		31	34	mA
Power dissipation ⁽⁸⁾		$f_s = 1.25\text{ MHz}$		155	170	mW
TEMPERATURE RANGE						
Operating free-air temperature			-40		85	$^{\circ}\text{C}$

(8) This includes only VA+ current. +VBD current is typically 1 mA with 5-pF load capacitance on output pins.

TIMING CHARACTERISTICS

All specifications typical at -40°C to 85°C , $+V_A = +V_{BD} = 5\text{ V}$ ⁽¹⁾⁽²⁾⁽³⁾

PARAMETER		MIN	TYP	MAX	UNIT
t_{CONV}	Conversion time			610	ns
t_{ACQ}	Acquisition time	150			ns
t_{HOLD}	Sampling capacitor hold time			25	ns
t_{pd1}	$\overline{\text{CONVST}}$ low to BUSY high			40	ns
t_{pd2}	Propagation delay time, end of conversion to BUSY low			15	ns
t_{pd3}	Propagation delay time, from start of conversion (internal state) to rising edge of BUSY			15	ns
t_{w1}	Pulse duration, $\overline{\text{CONVST}}$ low	20			ns
t_{su1}	Setup time, $\overline{\text{CS}}$ low to $\overline{\text{CONVST}}$ low	0			ns
t_{w2}	Pulse duration, $\overline{\text{CONVST}}$ high	20			ns
	$\overline{\text{CONVST}}$ falling edge jitter			10	ps
t_{w3}	Pulse duration, BUSY signal low	Min(t_{ACQ})			ns
t_{w4}	Pulse duration, BUSY signal high			610	ns
t_{h1}	Hold time, First data bus data transition ($\overline{\text{RD}}$ low, or $\overline{\text{CS}}$ low for read cycle, or BYTE input changes) after $\overline{\text{CONVST}}$ low	40			ns
t_{d1}	Delay time, $\overline{\text{CS}}$ low to $\overline{\text{RD}}$ low	0			ns
t_{su2}	Setup time, $\overline{\text{RD}}$ high to $\overline{\text{CS}}$ high	0			ns
t_{w5}	Pulse duration, $\overline{\text{RD}}$ low time	50			ns
t_{en}	Enable time, $\overline{\text{RD}}$ low (or $\overline{\text{CS}}$ low for read cycle) to data valid			20	ns
t_{d2}	Delay time, data hold from $\overline{\text{RD}}$ high	0			ns
t_{d3}	Delay time, BYTE rising edge or falling edge to data valid	2		20	ns
t_{w6}	Pulse duration, $\overline{\text{RD}}$ high	20			ns
t_{w7}	Pulse duration, $\overline{\text{CS}}$ high time	20			ns
t_{h2}	Hold time, last $\overline{\text{RD}}$ (or $\overline{\text{CS}}$ for read cycle) rising edge to $\overline{\text{CONVST}}$ falling edge	50			ns
t_{pd4}	Propagation delay time, BUSY falling edge to next $\overline{\text{RD}}$ (or $\overline{\text{CS}}$ for read cycle) falling edge	0			ns
t_{su3}	Setup time, BYTE transition to $\overline{\text{RD}}$ falling edge	0			ns
t_{h3}	Hold time, BYTE transition to $\overline{\text{RD}}$ falling edge	0			ns
t_{dis}	Disable time, $\overline{\text{RD}}$ high ($\overline{\text{CS}}$ high for read cycle) to 3-stated data bus			20	ns
t_{d5}	Delay time, BUSY low to MSB data valid			10	ns
t_{su4}	Byte transition setup time, from BYTE transition to next BYTE transition	50			ns
t_{d6}	Delay time, $\overline{\text{CS}}$ rising edge to BUSY falling edge	50			ns
t_{d7}	Delay time, BUSY falling edge to $\overline{\text{CS}}$ rising edge	50			ns
$t_{\text{su(AB)}}$	Setup time, from the falling edge of $\overline{\text{CONVST}}$ (used to start the valid conversion) to the next falling edge of $\overline{\text{CONVST}}$ (when $\overline{\text{CS}} = 0$ and $\overline{\text{CONVST}}$ used to abort) or to the next falling edge of $\overline{\text{CS}}$ (when $\overline{\text{CS}}$ is used to abort)	60		500	ns

- (1) All input signals are specified with $t_r = t_f = 5\text{ ns}$ (10% to 90% of $+V_{BD}$) and timed from a voltage level of $(V_{IL} + V_{IH})/2$.
- (2) See timing diagrams.
- (3) All timings are measured with 20-pF equivalent loads on all data bits and BUSY pins.

TIMING CHARACTERISTICS

All specifications typical at -40°C to 85°C , $+V_A = 5\text{ V}$, $+V_{BD} = 3\text{ V}$ ⁽¹⁾⁽²⁾⁽³⁾

PARAMETER	MIN	TYP	MAX	UNIT
t_{CONV} Conversion time			610	ns
t_{ACQ} Acquisition time	150			ns
t_{HOLD} Sampling capacitor hold time			25	ns
t_{pd1} $\overline{\text{CONVST}}$ low to BUSY high			50	ns
t_{pd2} Propagation delay time, end of conversion to BUSY low			25	ns
t_{pd3} Propagation delay time, from start of conversion (internal state) to rising edge of BUSY			25	ns
t_{w1} Pulse duration, $\overline{\text{CONVST}}$ low	20			ns
t_{su1} Setup time, $\overline{\text{CS}}$ low to $\overline{\text{CONVST}}$ low	0			ns
t_{w2} Pulse duration, $\overline{\text{CONVST}}$ high	20			ns
$\overline{\text{CONVST}}$ falling edge jitter			10	ps
t_{w3} Pulse duration, BUSY signal low	Min(t_{ACQ})			ns
t_{w4} Pulse duration, BUSY signal high			610	ns
t_{h1} Hold time, first data bus transition ($\overline{\text{RD}}$ low, or $\overline{\text{CS}}$ low for read cycle, or BYTE or BUS 16/16 input changes) after $\overline{\text{CONVST}}$ low	40			ns
t_{d1} Delay time, $\overline{\text{CS}}$ low to $\overline{\text{RD}}$ low	0			ns
t_{su2} Setup time, $\overline{\text{RD}}$ high to $\overline{\text{CS}}$ high	0			ns
t_{w5} Pulse duration, $\overline{\text{RD}}$ low	50			ns
t_{en} Enable time, $\overline{\text{RD}}$ low (or $\overline{\text{CS}}$ low for read cycle) to data valid			30	ns
t_{d2} Delay time, data hold from $\overline{\text{RD}}$ high	0			ns
t_{d3} Delay time, BYTE rising edge or falling edge to data valid	2		30	ns
t_{w6} Pulse duration, $\overline{\text{RD}}$ high time	20			ns
t_{w7} Pulse duration, $\overline{\text{CS}}$ high time	20			ns
t_{h2} Hold time, last $\overline{\text{RD}}$ (or $\overline{\text{CS}}$ for read cycle) rising edge to $\overline{\text{CONVST}}$ falling edge	50			ns
t_{pd4} Propagation delay time, BUSY falling edge to next $\overline{\text{RD}}$ (or $\overline{\text{CS}}$ for read cycle) falling edge	0			ns
t_{su3} Setup time, BYTE transition to $\overline{\text{RD}}$ falling edge	0			ns
t_{h3} Hold time, BYTE transition to $\overline{\text{RD}}$ falling edge	0			ns
t_{dis} Disable time, $\overline{\text{RD}}$ high ($\overline{\text{CS}}$ high for read cycle) to 3-stated data bus			30	ns
t_{d5} Delay time, BUSY low to MSB data valid delay time			10	ns
t_{su4} Byte transition setup time, from BYTE transition to next BYTE transition	50			ns
t_{d6} Delay time, $\overline{\text{CS}}$ rising edge to BUSY falling edge	50			ns
t_{d7} Delay time, BUSY falling edge to $\overline{\text{CS}}$ rising edge	50			ns
$t_{\text{su(AB)}}$ Setup time, from the falling edge of $\overline{\text{CONVST}}$ (used to start the valid conversion) to the next falling edge of $\overline{\text{CONVST}}$ (when $\overline{\text{CS}} = 0$ and $\overline{\text{CONVST}}$ used to abort) or to the next falling edge of $\overline{\text{CS}}$ (when $\overline{\text{CS}}$ is used to abort)	70		500	ns

- (1) All input signals are specified with $t_r = t_f = 5\text{ ns}$ (10% to 90% of $+V_{BD}$) and timed from a voltage level of $(V_{IL} + V_{IH})/2$.
- (2) See timing diagrams.
- (3) All timings are measured with 20-pF equivalent loads on all data bits and BUSY pins.

PIN ASSIGNMENTS

**PFB PACKAGE
(TOP VIEW)**

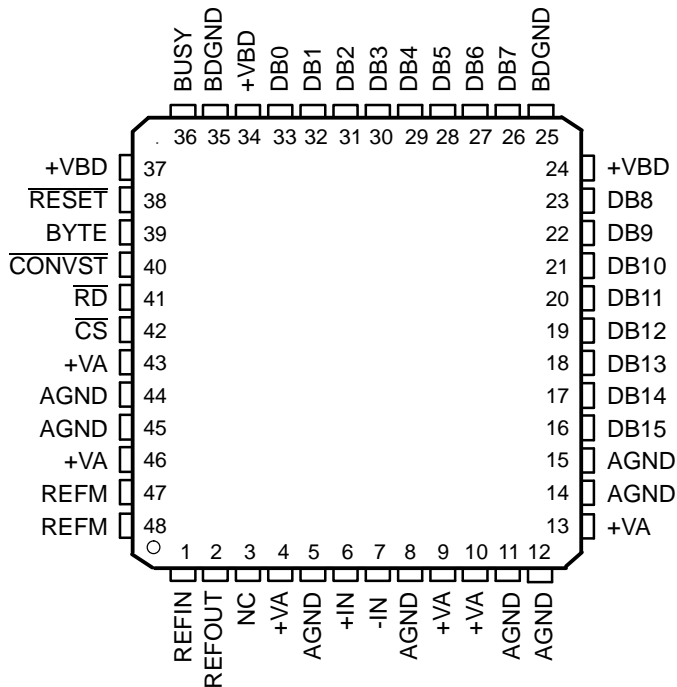

NC - No connection

Terminal Functions

NAME	NO.	I/O	DESCRIPTION		
AGND	5, 8, 11, 12, 14, 15, 44, 45	–	Analog ground		
BDGND	25, 35	–	Digital ground for bus interface digital supply		
BUSY	36	O	Status output. High when a conversion is in progress.		
BYTE	39	I	Byte select input. Used for 8-bit bus reading. 0: No fold back 1: Low byte D[7:0] of the 16 most significant bits is folded back to high byte of the 16 most significant pins DB[15:8].		
$\overline{\text{CONVST}}$	40	I	Convert start. The falling edge of this input ends the acquisition period and starts the hold period.		
$\overline{\text{CS}}$	42	I	Chip select. The falling edge of this input starts the acquisition period.		
Data Bus			8-Bit Bus		16-Bit Bus
			BYTE = 0	BYTE = 1	BYTE = 0
DB15	16	O	D15 (MSB)	D7	D15 (MSB)
DB14	17	O	D14	D6	D14
DB13	18	O	D13	D5	D13
DB12	19	O	D12	D4	D12
DB11	20	O	D11	D3	D11
DB10	21	O	D10	D2	D10
DB9	22	O	D9	D1	D9
DB8	23	O	D8	D0 (LSB)	D8
DB7	26	O	D7	All ones	D7
DB6	27	O	D6	All ones	D6
DB5	28	O	D5	All ones	D5
DB4	29	O	D4	All ones	D4
DB3	30	O	D3	All ones	D3
DB2	31	O	D2	All ones	D2
DB1	32	O	D1	All ones	D1
DB0	33	O	D0 (LSB)	All ones	D0 (LSB)
–IN	7	I	Inverting input channel		
+IN	6	I	Non inverting input channel		
NC	3	–	No connection		
REFIN	1	I	Reference input		
REFM	47, 48	I	Reference ground		
REFOUT	2	O	Reference output. Add 1- μ F capacitor between the REFOUT pin and REFM pin when internal reference is used.		
RESET	38	I	Current conversion is aborted and output latches are cleared (set to zeros) when this pin is asserted low. RESET works independantly of $\overline{\text{CS}}$.		
$\overline{\text{RD}}$	41	I	Synchronization pulse for the parallel output. When $\overline{\text{CS}}$ is low, this serves as the output enable and puts the previous conversion result on the bus.		
+VA	4, 9, 10, 13, 43, 46	–	Analog power supplies, 5-V dc		
+VBD	24, 34, 37	–	Digital power supply for bus		

TIMING DIAGRAMS

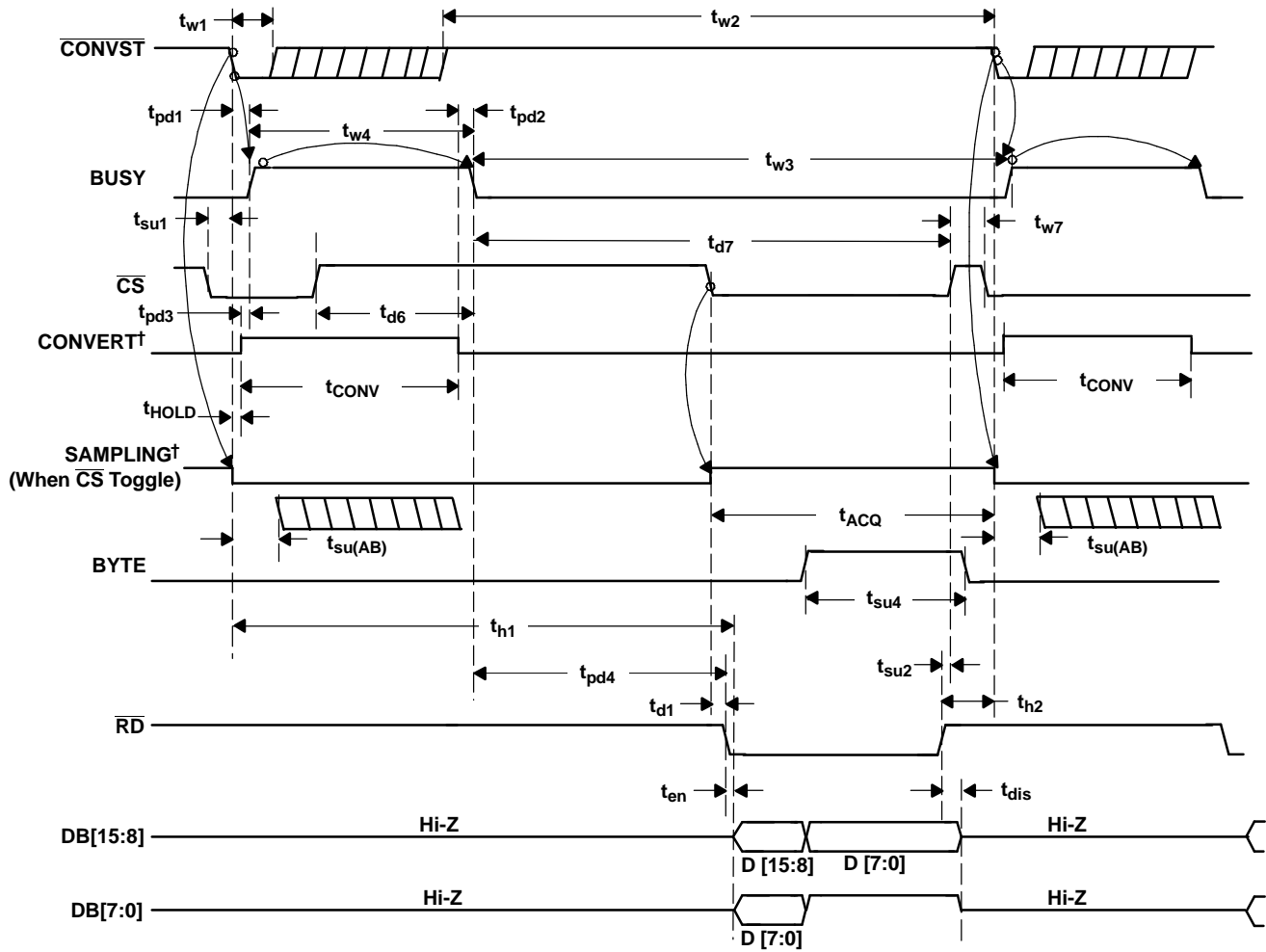

†Signal internal to device

Figure 1. Timing for Conversion and Acquisition Cycles With \overline{CS} and \overline{RD} Toggling

TIMING DIAGRAMS (continued)

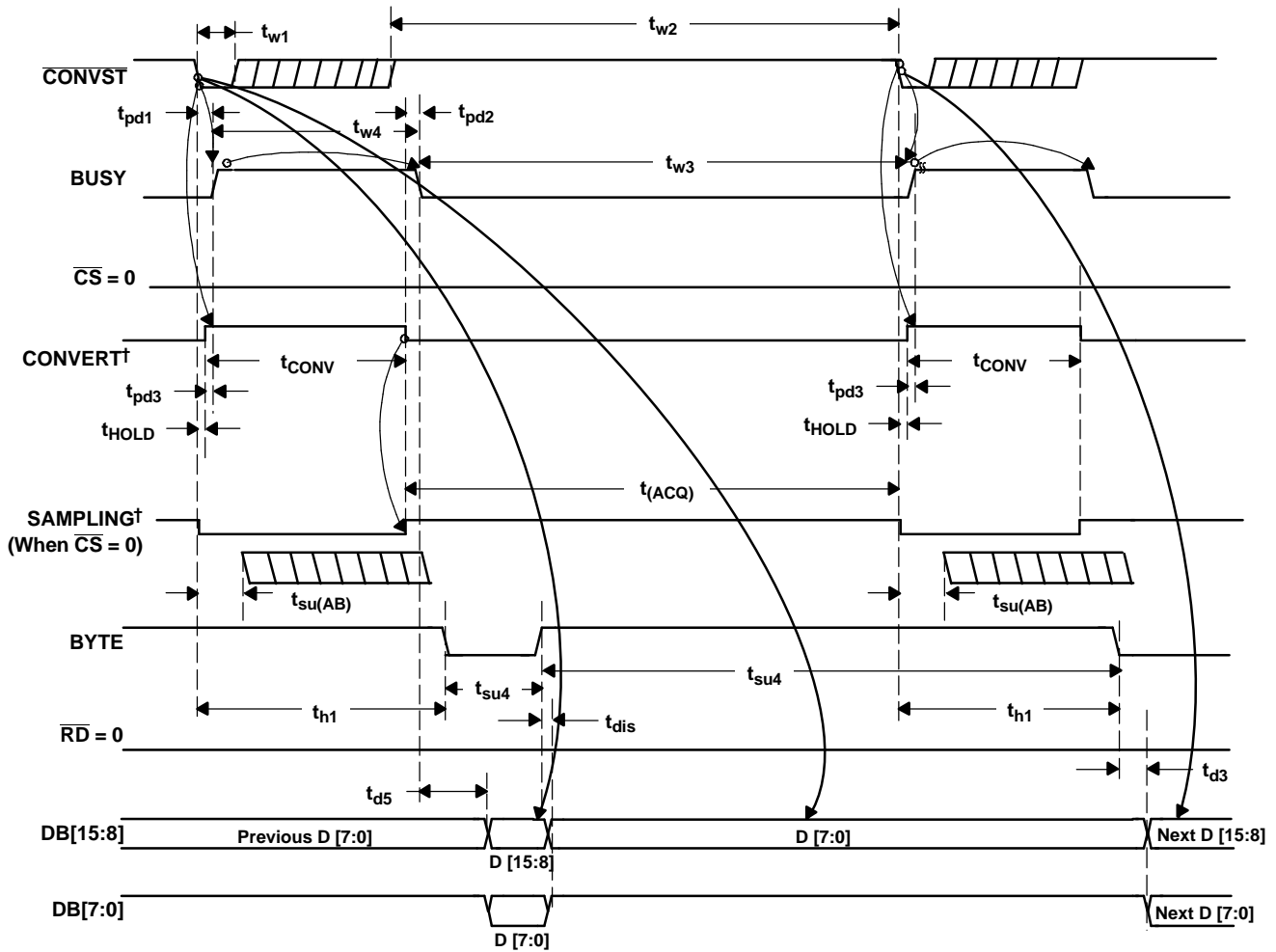

†Signal internal to device

Figure 4. Timing for Conversion and Acquisition Cycles With \overline{CS} and \overline{RD} Tied to BDGND—Auto Read

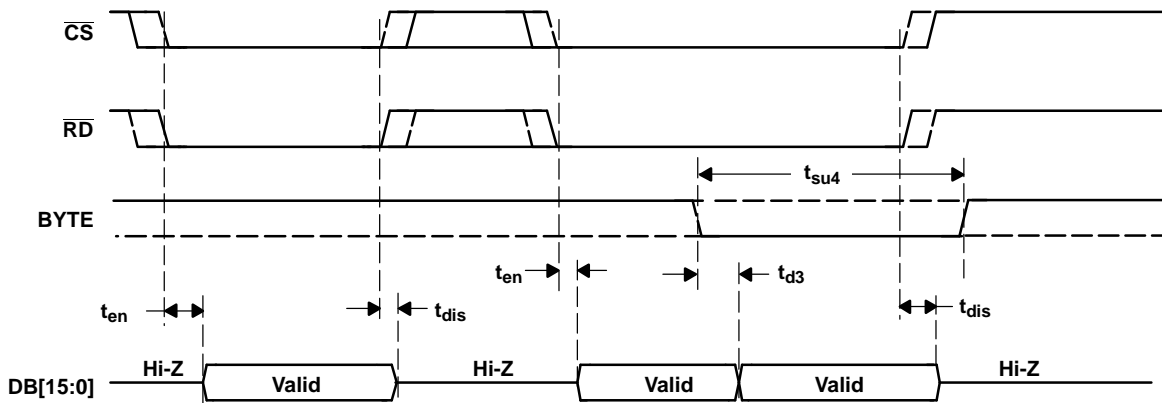

Figure 5. Detailed Timing for Read Cycles

TYPICAL CHARACTERISTICS

At -40°C to 85°C , $+V_A = 5\text{ V}$, $+V_{BD} = 5\text{ V}$, $\text{REFIN} = 4.096\text{ V}$ (internal reference used) and $f_{\text{sample}} = 1.25\text{ MHz}$ (unless otherwise noted)

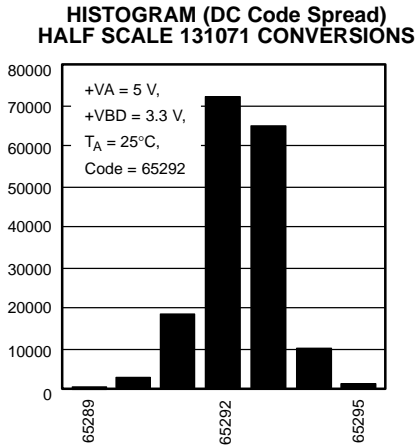

Figure 6.

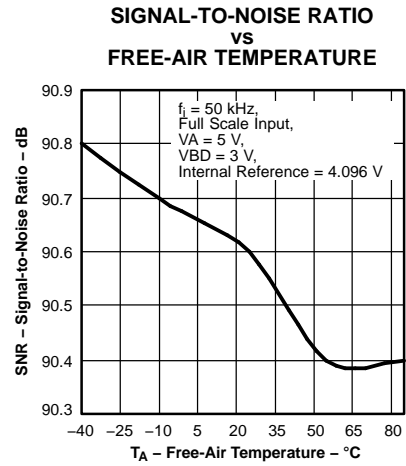

Figure 7.

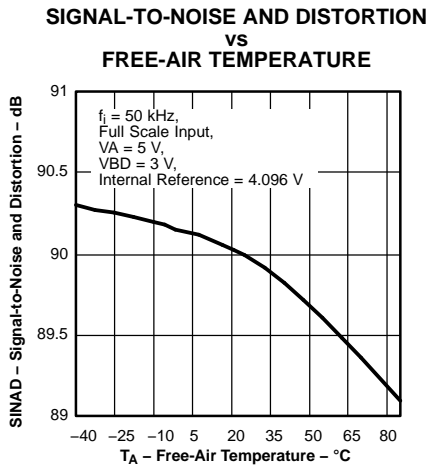

Figure 8.

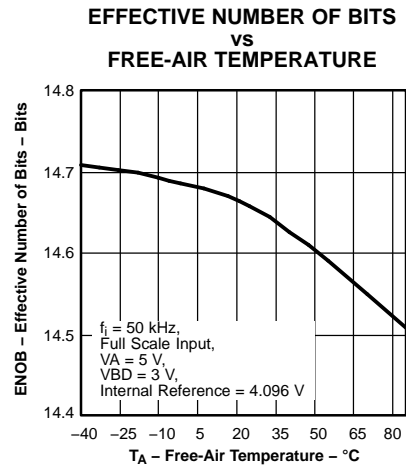

Figure 9.

TYPICAL CHARACTERISTICS (continued)

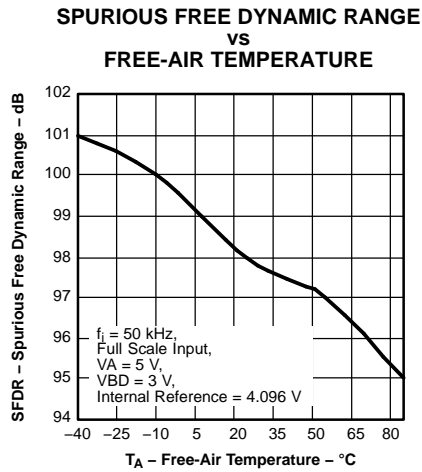

Figure 10.

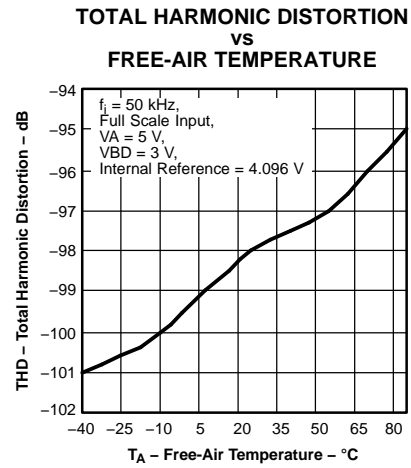

Figure 11.

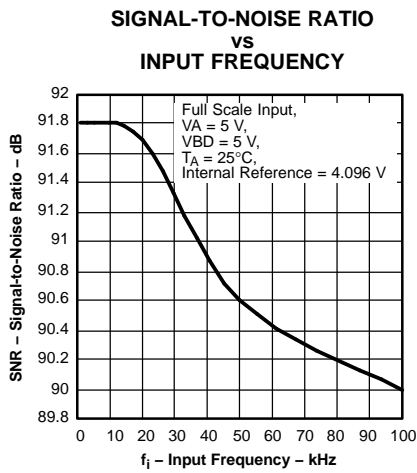

Figure 12.

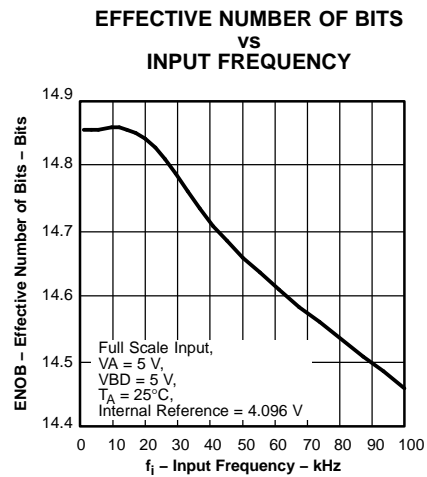

Figure 13.

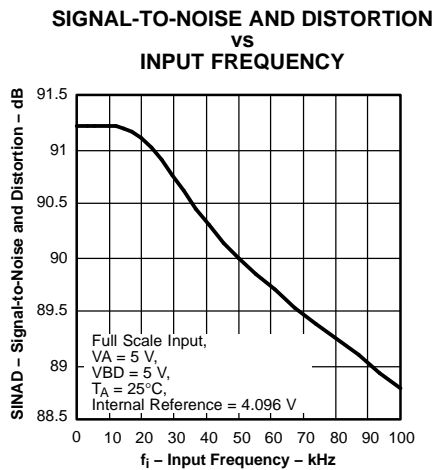

Figure 14.

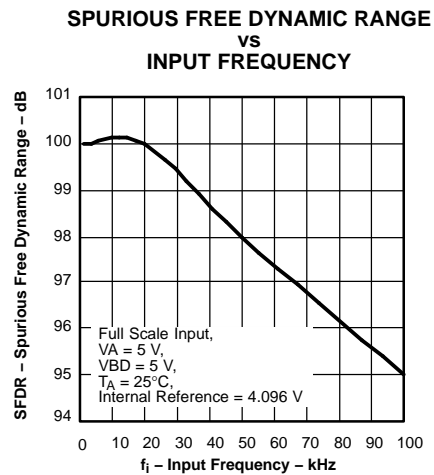

Figure 15.

TYPICAL CHARACTERISTICS (continued)

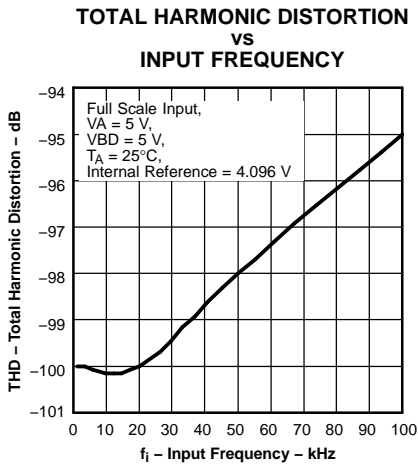

Figure 16.

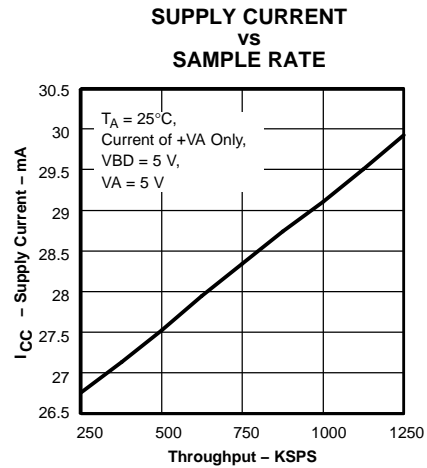

Figure 17.

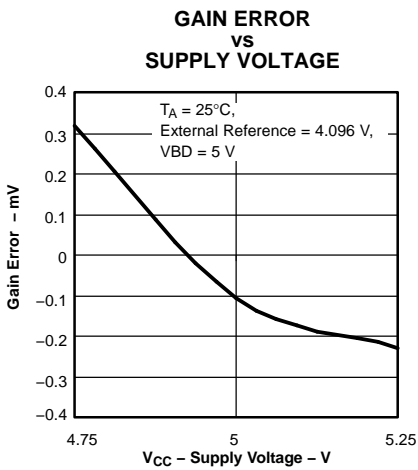

Figure 18.

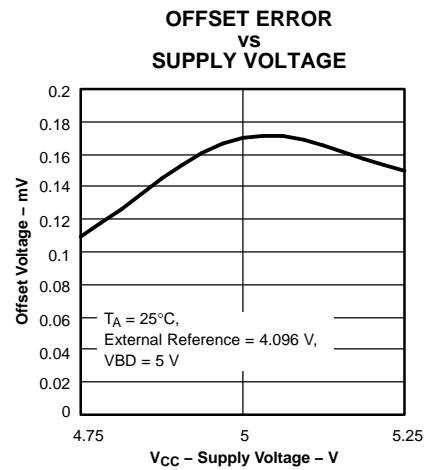

Figure 19.

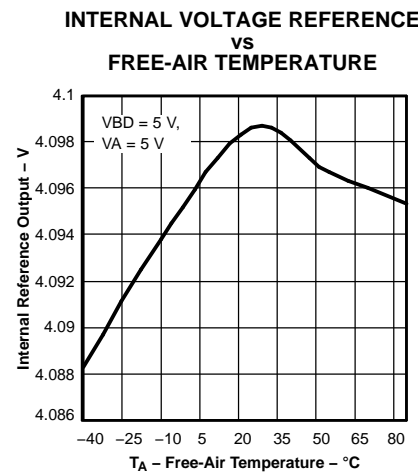

Figure 20.

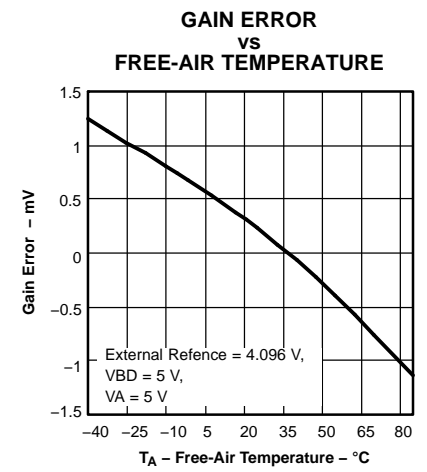

Figure 21.

TYPICAL CHARACTERISTICS (continued)

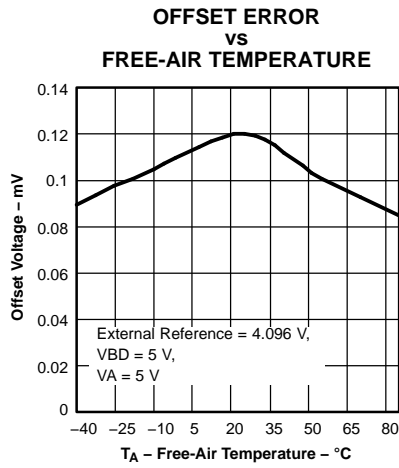

Figure 22.

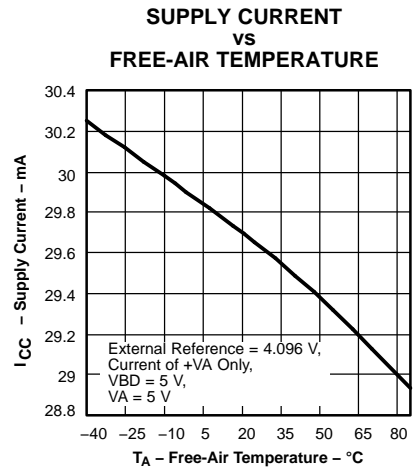

Figure 23.

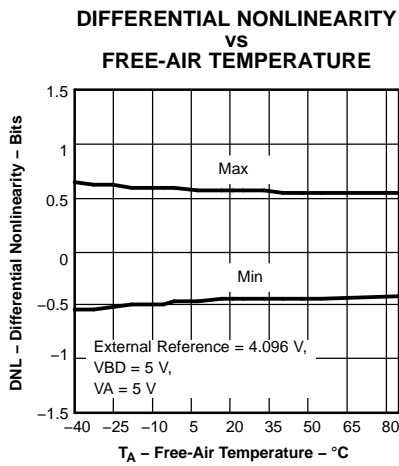

Figure 24.

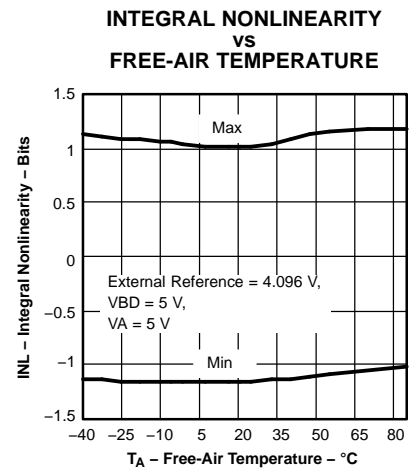

Figure 25.

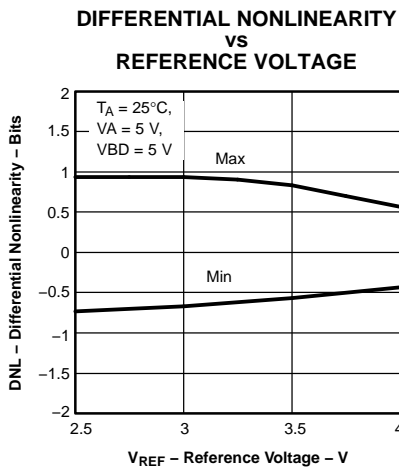

Figure 26.

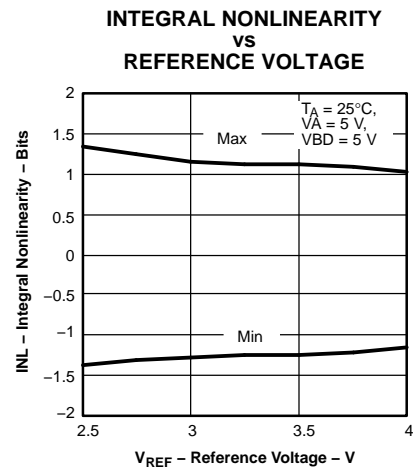

Figure 27.

TYPICAL CHARACTERISTICS (continued)

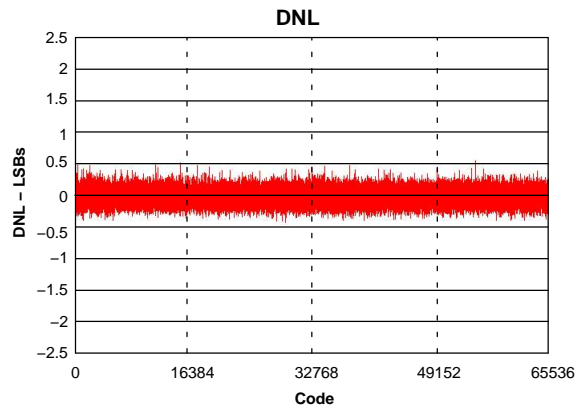

Figure 28.

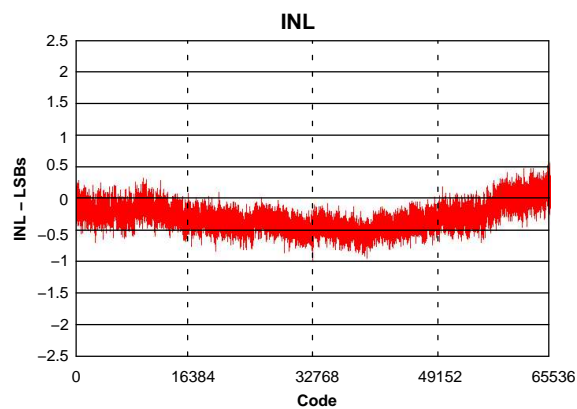

Figure 29.

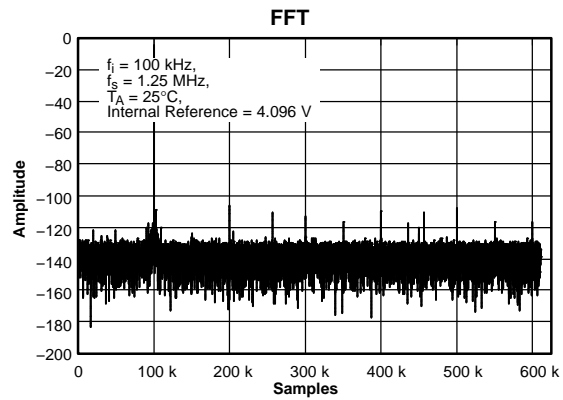

Figure 30.

APPLICATION INFORMATION

MICROCONTROLLER INTERFACING

ADS8406 to 8-Bit Microcontroller Interface

Figure 31 shows a parallel interface between the ADS8406 and a typical microcontroller using the 8-bit data bus. The BUSY signal is used as a falling-edge interrupt to the microcontroller.

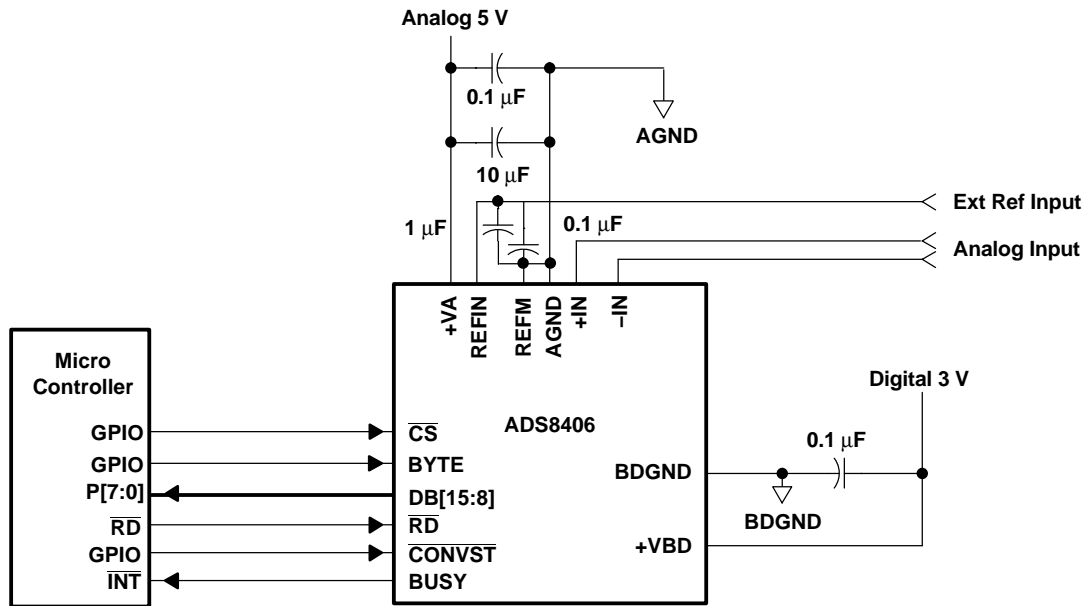

Figure 31. ADS8406 Application Circuitry (using external reference)

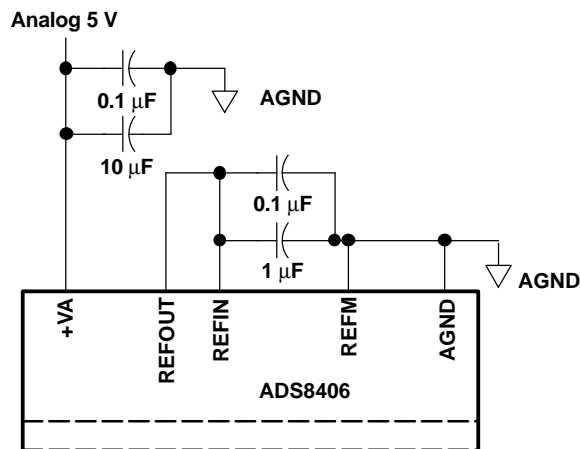

Figure 32. Use Internal Reference

PRINCIPLES OF OPERATION

The ADS8406 is a high-speed successive approximation register (SAR) analog-to-digital converter (ADC). The architecture is based on charge redistribution, which inherently includes a sample/hold function. See Figure 31 for the application circuit for the ADS8406.

The conversion clock is generated internally. The conversion time of 610 ns is capable of sustaining a 1.25-MHz throughput.

PRINCIPLES OF OPERATION (continued)

The analog input is provided to two input pins: +IN and –IN. When a conversion is initiated, the differential input on these pins is sampled on the internal capacitor array. While a conversion is in progress, both inputs are disconnected from any internal function.

REFERENCE

The ADS8406 can operate with an external reference with a range from 2.5 V to 4.2 V. A 4.096-V internal reference is included. When internal reference is used, pin 2 (REFOUT) should be connected to pin 1 (REFIN) with a 0.1- μ F decoupling capacitor and 1- μ F storage capacitor between pin 2 (REFOUT) and pins 47 and 48 (REFM) (see Figure 33). The internal reference of the converter is double buffered. If an external reference is used, the second buffer provides isolation between the external reference and the CDAC. This buffer is also used to recharge all of the capacitors of the CDAC during conversion. Pin 2 (REFOUT) can be left unconnected (floating) if external reference is used.

ANALOG INPUT

When the converter enters the hold mode, the voltage difference between the +IN and –IN inputs is captured on the internal capacitor array. Both +IN and –IN inputs have a range of -0.2 V to $V_{ref} + 0.2$ V. The input span (+IN – (–IN)) is limited to $-V_{ref}$ to V_{ref} .

The input current on the analog inputs depends upon a number of factors: sample rate, input voltage, and source impedance. Essentially, the current into the ADS8406 charges the internal capacitor array during the sample period. After this capacitance has been fully charged, there is no further input current. The source of the analog input voltage must be able to charge the input capacitance (25 pF) to an 16-bit settling level within the acquisition time (150 ns) of the device. When the converter goes into the hold mode, the input impedance is greater than 1 G Ω .

Care must be taken regarding the absolute analog input voltage. To maintain the linearity of the converter, the +IN and –IN inputs and the span (+IN – (–IN)) should be within the limits specified. Outside of these ranges, the converter's linearity may not meet specifications. To minimize noise, low bandwidth input signals with low-pass filters should be used.

Care should be taken to ensure that the output impedance of the sources driving +IN and –IN inputs are matched. If this is not observed, the two inputs could have different settling time. This may result in offset error, gain error and linearity error which varies with temperature and input voltage.

A typical input circuit using TI's THS4503 is shown in Figure 33. Input from a single-ended source may be converted into a differential signal for the ADS8406 as shown in the figure. In case the source itself is differential, then the THS4503 may be used in differential input and differential output modes.

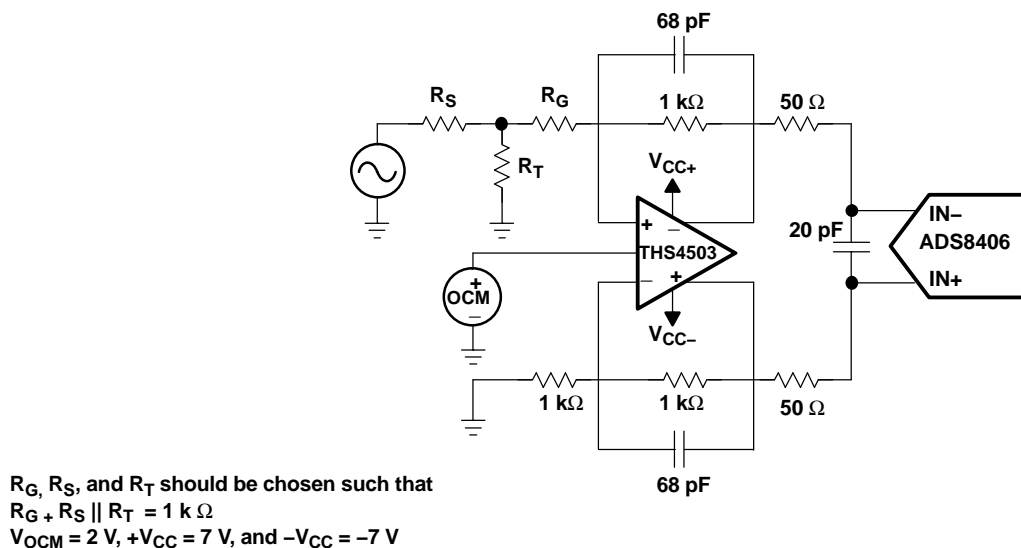

Figure 33. Using the THS4503 With the ADS8406

PRINCIPLES OF OPERATION (continued)

DIGITAL INTERFACE

Timing And Control

See the timing diagrams in the specifications section for detailed information on timing signals and their requirements.

The ADS8406 uses an internal oscillator generated clock which controls the conversion rate and in turn the throughput of the converter. No external clock input is required.

Conversions are initiated by bringing the $\overline{\text{CONVST}}$ pin low for a minimum of 20 ns (after the 20 ns minimum requirement has been met, the $\overline{\text{CONVST}}$ pin can be brought high), while $\overline{\text{CS}}$ is low. The ADS8406 switches from the sample to the hold mode on the falling edge of the $\overline{\text{CONVST}}$ command. A clean and low jitter falling edge of this signal is important to the performance of the converter. The BUSY output is brought high after $\overline{\text{CONVST}}$ goes low. BUSY stays high throughout the conversion process and returns low when the conversion has ended.

Sampling starts with the falling edge of the BUSY signal when $\overline{\text{CS}}$ is tied low or starts with the falling edge of $\overline{\text{CS}}$ when BUSY is low.

Both $\overline{\text{RD}}$ and $\overline{\text{CS}}$ can be high during and before a conversion with one exception ($\overline{\text{CS}}$ must be low when $\overline{\text{CONVST}}$ goes low to initiate a conversion). Both the $\overline{\text{RD}}$ and $\overline{\text{CS}}$ pins are brought low in order to enable the parallel output bus with the conversion.

Reading Data

The ADS8406 outputs full parallel data in two's complement format as shown in Table 1. The parallel output is active when $\overline{\text{CS}}$ and $\overline{\text{RD}}$ are both low. There is a minimal quiet zone requirement around the falling edge of $\overline{\text{CONVST}}$. This is 50 ns prior to the falling edge of $\overline{\text{CONVST}}$ and 40 ns after the falling edge. No data read should be attempted within this zone. Any other combination of $\overline{\text{CS}}$ and $\overline{\text{RD}}$ sets the parallel output to 3-state. BYTE is used for multiword read operations. BYTE is used whenever lower bits of the converter result are output on the higher byte of the bus. Refer to Table 1 for ideal output codes.

Table 1. Ideal Input Voltages and Output Codes

DESCRIPTION	ANALOG VALUE	DIGITAL OUTPUT	
		2'S COMPLEMENT	
Full scale range	$2(+V_{ref})$		
Least significant bit (LSB)	$2(+V_{ref})/65536$	BINARY CODE	HEX CODE
+Full scale	$(+V_{ref}) - 1 \text{ LSB}$	0111 1111 1111 1111	7FFF
Midscale	0 V	0000 0000 0000 0000	0000
Midscale – 1 LSB	0 V – 1 LSB	1111 1111 1111 1111	FFFF
– Full scale	$(-V_{ref})$	1000 0000 0000 0000	8000

The output data is a full 16-bit word (D15–D0) on DB15–DB0 pins (MSB–LSB) if BYTE is low.

The result may also be read on an 8-bit bus for convenience. This is done by using only pins DB15–DB8. In this case two reads are necessary: the first as before, leaving BYTE low and reading the 8 most significant bits on pins DB15–DB8, then bringing BYTE high. When BYTE is high, the low bits (D7–D0) appear on pins DB15–D8.

These multiword read operations can be done with multiple active $\overline{\text{RD}}$ (toggling) or with $\overline{\text{RD}}$ tied low for simplicity.

Conversion Data Readout

BYTE	DATA READ OUT	
	DB15–DB8 Pins	DB7–DB0 Pins
High	D7–D0	All one's
Low	D15–D8	D7–D0

RESET

$\overline{\text{RESET}}$ is an asynchronous active low input signal (that works independently of $\overline{\text{CS}}$). Minimum $\overline{\text{RESET}}$ low time is 25 ns. Current conversion will be aborted no later than 50 ns after the converter is in the reset mode. In addition, all output latches are cleared (set to zero's) after $\overline{\text{RESET}}$. The converter goes back to normal operation mode no later than 20 ns after $\overline{\text{RESET}}$ input is brought high.

The converter starts the first sampling period 20 ns after the rising edge of $\overline{\text{RESET}}$. Any sampling period except for the one immediately after a $\overline{\text{RESET}}$ is started with the falling edge of the previous BUSY signal or the falling edge of CS, whichever is later.

Another way to reset the device is through the use of the combination of $\overline{\text{CS}}$ and $\overline{\text{CONVST}}$. This is useful when the dedicated $\overline{\text{RESET}}$ pin is tied to the system reset but there is a need to abort only the conversion in a specific converter. Since the BUSY signal is held high during the conversion, either one of these conditions triggers an internal self-clear reset to the converter just the same as a reset via the dedicated $\overline{\text{RESET}}$ pin. The reset does not have to be cleared as for the dedicated $\overline{\text{RESET}}$ pin. A reset can be started with either of the two following steps.

- Issue a $\overline{\text{CONVST}}$ when $\overline{\text{CS}}$ is low and a conversion is in progress. The falling edge of $\overline{\text{CONVST}}$ must satisfy the timing as specified by the timing parameter $t_{\text{su(AB)}}$ mentioned in the timing characteristics table to ensure a reset. The falling edge of $\overline{\text{CONVST}}$ starts a reset. Timing is the same as a reset using the dedicated $\overline{\text{RESET}}$ pin except the instance of the falling edge is replaced by the falling edge of $\overline{\text{CONVST}}$.
- Issue a $\overline{\text{CS}}$ while a conversion is in progress. The falling edge of $\overline{\text{CS}}$ must satisfy the timing as specified by the timing parameter $t_{\text{su(AB)}}$ mentioned in the timing characteristics table to ensure a reset. The falling edge of $\overline{\text{CS}}$ causes a reset. Timing is the same as a reset using the dedicated $\overline{\text{RESET}}$ pin except the instance of the falling edge is replaced by the falling edge of $\overline{\text{CS}}$.

POWER-ON INITIALIZATION

RESET is not required after power on. An internal power-on-reset circuit generates the reset. To ensure that all of the registers are cleared, the three conversion cycles must be given to the converter after power on.

LAYOUT

For optimum performance, care should be taken with the physical layout of the ADS8406 circuitry.

As the ADS8406 offers single-supply operation, it is often used in close proximity with digital logic, microcontrollers, microprocessors, and digital signal processors. The more digital logic present in the design and the higher the switching speed, the more difficult it is to achieve good performance from the converter.

The basic SAR architecture is sensitive to glitches or sudden changes on the power supply, reference, ground connections and digital inputs that occur just prior to latching the output of the analog comparator. Thus, driving any single conversion for an n-bit SAR converter, there are at least n *windows* in which large external transient voltages can affect the conversion result. Such glitches might originate from switching power supplies, nearby digital logic, or high power devices.

The degree of error in the digital output depends on the reference voltage, layout, and the exact timing of the external event.

On average, the ADS8406 draws very little current from an external reference, as the reference voltage is internally buffered. If the reference voltage is external and originates from an op amp, make sure that it can drive the bypass capacitor or capacitors without oscillation. A 0.1- μF bypass capacitor and a 1- μF storage capacitor are recommended from pin 1 (REFIN) directly to pin 48 (REFM). REFM and AGND should be shorted on the same ground plane under the device.

The AGND and BDGND pins should be connected to a clean ground point. In all cases, this should be the analog ground. Avoid connections which are close to the grounding point of a microcontroller or digital signal processor. If required, run a ground trace directly from the converter to the power supply entry point. The ideal layout consists of an analog ground plane dedicated to the converter and associated analog circuitry.

As with the AGND connections, +VA should be connected to a 5-V power supply plane or trace that is separate from the connection for digital logic until they are connected at the power entry point. Power to the ADS8406 should be clean and well bypassed. A 0.1- μ F ceramic bypass capacitor should be placed as close to the device as possible. See Table 2 for the placement of the capacitor. In addition, a 1- μ F to 10- μ F capacitor is recommended. In some situations, additional bypassing may be required, such as a 100- μ F electrolytic capacitor or even a Pi filter made up of inductors and capacitors—all designed to essentially low-pass filter the 5-V supply, removing the high frequency noise.

Table 2. Power Supply Decoupling Capacitor Placement

POWER SUPPLY PLANE	CONVERTER ANALOG SIDE	CONVERTER DIGITAL SIDE
SUPPLY PINS		
Pin pairs that require shortest path to decoupling capacitors	(4,5), (8,9), (10,11), (13,15), (43,44), (45,46)	(24,25), (34, 35)
Pins that require no decoupling	12, 14	37

PFB (S-PQFP-G48)

PLASTIC QUAD FLATPACK

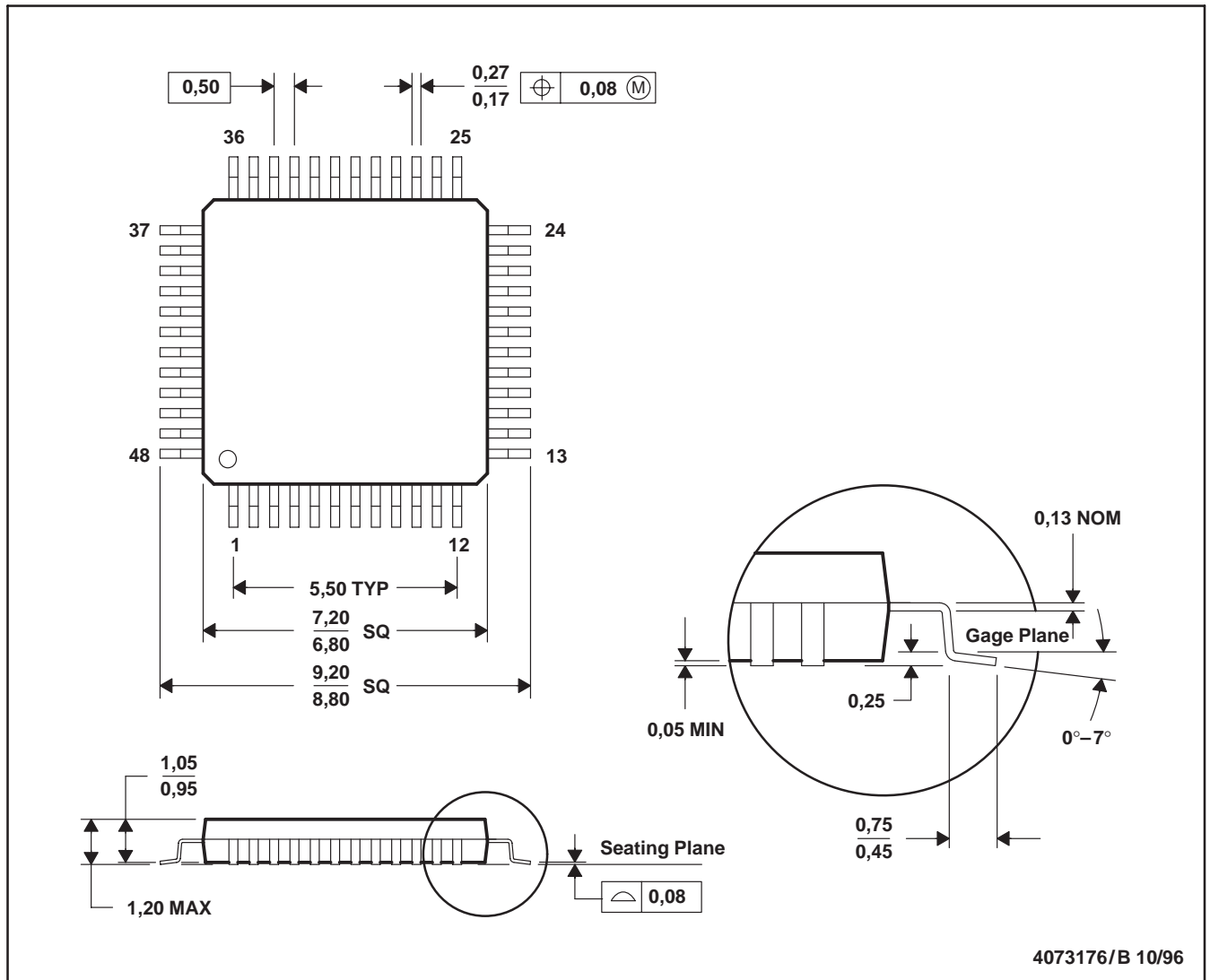

- NOTES: A. All linear dimensions are in millimeters.
 B. This drawing is subject to change without notice.
 C. Falls within JEDEC MS-026

IMPORTANT NOTICE

Texas Instruments Incorporated and its subsidiaries (TI) reserve the right to make corrections, modifications, enhancements, improvements, and other changes to its products and services at any time and to discontinue any product or service without notice. Customers should obtain the latest relevant information before placing orders and should verify that such information is current and complete. All products are sold subject to TI's terms and conditions of sale supplied at the time of order acknowledgment.

TI warrants performance of its hardware products to the specifications applicable at the time of sale in accordance with TI's standard warranty. Testing and other quality control techniques are used to the extent TI deems necessary to support this warranty. Except where mandated by government requirements, testing of all parameters of each product is not necessarily performed.

TI assumes no liability for applications assistance or customer product design. Customers are responsible for their products and applications using TI components. To minimize the risks associated with customer products and applications, customers should provide adequate design and operating safeguards.

TI does not warrant or represent that any license, either express or implied, is granted under any TI patent right, copyright, mask work right, or other TI intellectual property right relating to any combination, machine, or process in which TI products or services are used. Information published by TI regarding third-party products or services does not constitute a license from TI to use such products or services or a warranty or endorsement thereof. Use of such information may require a license from a third party under the patents or other intellectual property of the third party, or a license from TI under the patents or other intellectual property of TI.

Reproduction of information in TI data books or data sheets is permissible only if reproduction is without alteration and is accompanied by all associated warranties, conditions, limitations, and notices. Reproduction of this information with alteration is an unfair and deceptive business practice. TI is not responsible or liable for such altered documentation.

Resale of TI products or services with statements different from or beyond the parameters stated by TI for that product or service voids all express and any implied warranties for the associated TI product or service and is an unfair and deceptive business practice. TI is not responsible or liable for any such statements.

Following are URLs where you can obtain information on other Texas Instruments products and application solutions:

Products		Applications	
Amplifiers	amplifier.ti.com	Audio	www.ti.com/audio
Data Converters	dataconverter.ti.com	Automotive	www.ti.com/automotive
DSP	dsp.ti.com	Broadband	www.ti.com/broadband
Interface	interface.ti.com	Digital Control	www.ti.com/digitalcontrol
Logic	logic.ti.com	Military	www.ti.com/military
Power Mgmt	power.ti.com	Optical Networking	www.ti.com/opticalnetwork
Microcontrollers	microcontroller.ti.com	Security	www.ti.com/security
		Telephony	www.ti.com/telephony
		Video & Imaging	www.ti.com/video
		Wireless	www.ti.com/wireless

Mailing Address: Texas Instruments
Post Office Box 655303 Dallas, Texas 75265

Copyright © 2004, Texas Instruments Incorporated